

Early Stage 1 Learning Grid Week 9

Monday	Tuesday	Wednesday	Thursday	Friday	Extra Activities
--------	---------	-----------	----------	--------	------------------

English

Practice all sounds and sight we have learnt so far **every day**.

Sounds, Letters, Sight Words

New Digraph Ending Sound: **ng**
New sight words **are, other, many, out.**

When you have two letters together and they make a single sound, they are called a digraph. A digraph can be at the beginning, middle or end of a word.

This week we are focusing on this sound at the end of words.

Listen to the link (if you can) to hear the sound and how to make the sound **ng**.

<https://www.youtube.com/watch?v=Nrjb0rler5M>

Sort the **ng ending** words into ang, ing, ong, ung.

Words ending with -ng

Read the words and write them under the correct ending sound.

-ang	-ing	-ong	-ung

bang	cling	strong	strung	flung
long	clang	tongs	swung	thing
sung	sling	wing	sprang	song
fang	hang	belong	string	lung

Sounds, Letters, Sight Words

Practise your new sound **ng** and sight words **are, other, many, out.**

Listen to and join in with the link below.

<https://www.youtube.com/watch?v=jmtOKfTEBh8&t=31s>

Find the **ng** words hiding in the grid, cross them off and choose 3 at the end to write a sentence.



I Spy a sight word...

Play this with someone else. Put all words out face up on the floor or table. Take turns, I spy with my little eye a word.... say the beginning, middle or ending sound. If the person guesses correctly, they get to keep the word. **Eg. I spy a word with the soft sound 'th' in the middle?**
Answer: other!

SATPIN Video

Watch the SATPIN video in Google Classroom for practise making words.

Sounds, Letters, Sight Words

Practise your new sound **ng** and sight words **are, other, many, out.**

Complete the attached **ng** worksheet. Say and write the **ng** words.

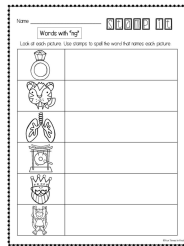

Swat the sight word



Play with someone at home, they call out the word, you swat it.

Sounds, Letters, Sight Words

Practise your new sound **ng** and sight words **are, other, many, out.**

Sight word Spell

Ask someone at home to test you spelling out the letters of your sight words. They say it, you spell it. If you get it right you get to keep it.

Challenge yourself by not looking at the word whilst you spell it.

SATPIN Video

Watch the SATPIN video in Google Classroom for practise making words.

Sounds, Letters, Sight Words

Practise your new sound **ng** and sight words **are, other, many, out.**

Poem

Read the poem below. Can you make a short poem with some rhyming **ng** words?

On the Ning Nang Nong
By Spike Milligan

*On the Ning Nang Nong
Where the cows go "Bong!" and
the monkeys all say "Boo!"*

*There's a Nong Nang Ning
Where the trees go "Ping!"
And the tea pots jibber jabber
joo!*

*On the Nong Ning Nang,
All the mice go "Clang!"
And you just can't catch 'em
when they do!*

*So it's Ning Nang Nong,
Cows go "Bong!"*

*Nong Nang Ning,
Trees go "Ping!"*

*Nong Ning Nang,
The mice go "Clang!"*

*What a noisy place to belong
Is the Ning Nang, Ning Nang,
Nong!*

Sounds, Letters, Sight Words









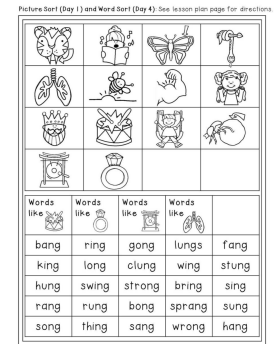







Make a word wall if you haven't already. This is a spot where all your sight words can be seen clearly and easily. You could use a wall, however, a door or window would work too. Be creative and do what works at your house.

You could use printed words or make your own with some fun coloured texters to make an artwork.

Extra worksheets below:



<p>Writing</p> <p>Handwriting: Complete the handwriting practice worksheets uploaded to GC.</p> <p>Follow the handwriting video uploaded to Google Classroom. Letters p, i, n.</p> <p>are, other, many, out.</p> <p>Make copies or write the new words out and put them somewhere you can see them.</p>	<p>Writing</p> <p>Write your new sight words: are, other, many, out.</p> <p>How many can you get into one sentence? Or write each word in a sentence.</p> <p>Use punctuation Capital letter, finger spaces, full stop, or do you need a question mark or an exclamation mark? </p> <p>Remember Good writers re-read and check their writing. Does it make sense?</p>	<p>Writing</p> <p>Follow the sentence lesson uploaded to your Google Classroom.</p> <p>Who What Where When</p> <p>Write a sentence that shows these 4 'w' words. Eg: The black cat sat under the tree in the park on a sunny day. OR On a sunny day the black cat sat under the tree in the park.</p>	<p>Writing</p> <p>Rainbow write your new sight words and other sight words you need to practise.</p> 	<p>Writing</p> <p>ng worksheet – write the ng words.</p> <table border="1" data-bbox="1489 207 1780 614"> <tr> <td>Name: _____</td> <td>Date: _____</td> </tr> <tr> <td>ng </td> <td>rung _____ hang _____ string _____ song _____</td> </tr> <tr> <td>ring </td> <td>so__ _____ bri__ _____ wi__ _____</td> </tr> <tr> <td>lo__ _____ </td> <td></td> </tr> <tr> <td>Bring a long string. </td> <td></td> </tr> </table>	Name: _____	Date: _____	ng 	rung _____ hang _____ string _____ song _____	ring 	so__ _____ bri__ _____ wi__ _____	lo__ _____ 		Bring a long string. 		<p>Writing</p> <p>E-mail: Your teacher is wondering about your week. Send her an e-mail with a sentence about what your favourite thing in the week is and why. How can you start?</p> <p>Dear Mrs _____ My favourite thing this week was _____ because _____</p> <p>From _____.</p>
Name: _____	Date: _____														
ng 	rung _____ hang _____ string _____ song _____														
ring 	so__ _____ bri__ _____ wi__ _____														
lo__ _____ 															
Bring a long string. 															
<p>Reading</p> <p>Focus on reading your decodable readers.</p> <p>Remember to:</p> <ul style="list-style-type: none"> - Point to each word as you read - Decode the words by blending your sounds - Be fluent (read like a river) <p>Please send your weekly video reading your decodable reader by GC or your teachers e-mail.</p>	<p>Reading</p> <p>Focus on reading your decodable readers.</p> <p>Remember to:</p> <ul style="list-style-type: none"> - Point to each word as you read - Decode the words by blending your sounds - Be fluent (read like a river) <p>Please send your weekly video reading your decodable reader by GC or your teachers e-mail.</p>	<p>Reading</p> <p>Focus on reading your decodable readers.</p> <p>Remember to:</p> <ul style="list-style-type: none"> - Point to each word as you read - Decode the words by blending your sounds - Be fluent (read like a river) <p>Please send your weekly video reading your decodable reader by GC or your teachers e-mail.</p>	<p>Reading</p> <p>Focus on reading your decodable readers.</p> <p>Remember to:</p> <ul style="list-style-type: none"> - Point to each word as you read - Decode the words by blending your sounds - Be fluent (read like a river) <p>Please send your weekly video reading your decodable reader by GC or your teachers e-mail.</p>	<p>Reading</p> <p>Focus on reading your decodable readers.</p> <p>Remember to:</p> <ul style="list-style-type: none"> - Point to each word as you read - Decode the words by blending your sounds - Be fluent (read like a river) <p>Please send your weekly video reading your decodable reader by GC or your teachers e-mail.</p>	<p>Reading</p> <p>Use epic to read https://www.getepic.com/sign-in</p> <p>What was the problem in the story? How was the problem solved?</p> 										

Maths

Continue counting forward to 100 and backward from 10, 20 or more, write numbers using correct formation and order from 0 - 20 each day (numeral cards to cut out are below) 😊

Finding difference (Revision)

Use a pack of dominoes or the domino cards below. Flip over a domino and find the difference between the dots by adding to the smaller number or subtracting from the larger number.

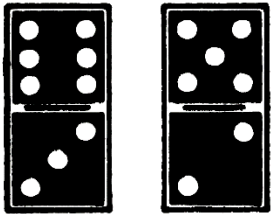

For example:

Left domino: Find the difference between 6 and 3.

Right domino: Find the difference between 5 and 2.

Friends of 10 (Revision)

Complete the worksheet below by colouring in the number of dots on the left side.

Let's Make Ten

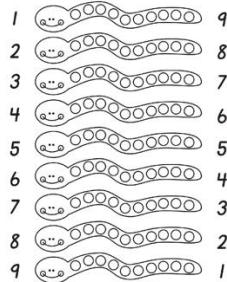

It should look like this once coloured in:

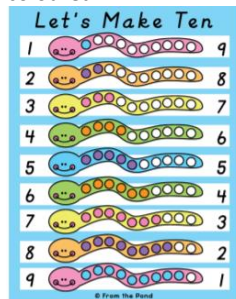

Partitioning (Revision)

Revise:
What is partitioning?

Use blocks or other small objects to partition the numbers: 5, 6, 7, 8, 9, 10. Partition each number into as many ways you can and record your work by drawing it or taking photos.

Challenge: Partition numbers between 10-20.



Comparing volume

Watch the following video on comparing volume.

<https://vimeo.com/587626197/2ea126d28d>

Comparing volume

Find two different sized 3D objects in your house. Investigate which object is larger and which object is smaller by comparing the volume. Put them side by side, or one in front of the other to determine which has a larger volume.

Volume hunt

Start with a biscuit box or cereal box. Walk around the house or backyard and find objects that have a smaller volume and then a larger volume. Remember to look at all 3 dimensions of the object to determine which is larger.

Capacity

Watch the following video to find out about capacity.

<https://vimeo.com/587626150/8c6e6fe502>













Investigate capacity by finding two different sized buckets or cups and pour liquid from one to the other find out which has the larger capacity.

Complete the worksheet:

Name: _____ Date: _____

Volume and Capacity

Colour the item that holds less.

 spoon	 jug	 bucket	 cup
 wheelbarrow	 bucket	 kettle	 bucket
 spoon	 vase	 bucket	 bowl
 carton	 bucket	 vase	 trashcan

Revision

Choose a topic you need to practice.
Friends of 10: Ask a family member to hold up a number card so you can tell them it's friend of 10.
Partitioning: Practice partitioning using your hands. Ask someone in your family to give you a number and use your fingers to partition.
Cards addition or subtraction: Make two piles with a pack of cards and turn a card from each pile over. Practice adding both cards, or subtracting the smaller number from the higher number. If needed have counters or small objects out to help you work out the answer.

Addition colouring

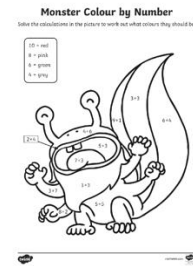

Other

Wellbeing – Strengths and Challenges

This week you will be learning about identifying your own strengths and challenges. Click on the following You-Tube link to learn all about strengths and challenges if you have access.

Art – Spring Craft

Complete the Spring Craft activity. The template is attached to this week's grid. Use your thumbprints to create leaves for your tree. As it is Spring, you can use more than one colour if you wish. It is entirely up to you.

Speaking and Listening

Continue to practise your 'Caring for a pet' presentation which is to be presented in Week 9 in your zoom meetings.

Check your Google Classroom for the timetable.

PE - Exercise Drills:

Rest for 10 seconds between each drill.

- 20-star jumps
- Jog on the spot while counting to 20
- 10 squats
- 5 sit ups
- 5 push ups

Science – Living Things

Complete the attached living things activity sheet.

Have a think about what food you eat and what you drink. Draw them on the worksheet. Do you know why we need to eat food and drink water? Talk

Construction/Free choice

It's the end of the week! You have free choice! Some ideas are games, construction, or an activity outside of your choice.



<https://www.youtube.com/watch?v=z0kQqbVUAUFG>

Some questions for discussion at home:

- *What is the difference between a strength and a challenge?
- * Why is it important to identify your own strengths and challenges?
- * How can setting goals and practising your challenges daily help you to improve your skills?

Use the Strengths and Challenges recording sheet to write 5 strengths and 5 challenges you face. Then write of 1 strength that you feel confident in, and how it helps you to complete a task. Finally, write about one challenge you feel you may need help with.

My Strengths and Challenges

Task: List 5 different strengths that you believe you have, followed by 5 challenges you face in the boxes below. Then choose one strength and explain how it helps you feel confident at a particular thing. Finally choose one challenge and explain how you could use some help to turn it into a strength.

My Strengths:	My Challenges:
➡	➡
➡	➡
➡	➡
➡	➡
➡	➡

I feel confident at:

I need help with:



Taking Care of Your Pet



- 10 jumps
- Skipping while counting to 30.
- Balancing and walking along a line to the end and back.



to an adult about what you think.

Now think about your pet or Pig the Pug. What does your chosen pet eat? What do they drink? Is it the same as a person? Draw what your chosen pet eats and drinks.

If you can, watch the video on Google Classroom with Mrs Parnell.

Eating and Drinking

What does your pet eat?	What does your pet drink?



Words ending with -ng

Read the words and write them under the correct ending sound.

-ang	-ing	-ong	-ung

bang	cling	strong	strung	flung
long	clang	tongs	swung	thing
sung	sting	wing	sprang	song
fang	hang	belong	string	lung

Name _____

Find the words that end with -ng.

s t r u n g c h r
s t r o n g l a u
r w a c k i n o
v r e t h i n g p
n t l y j k g f l
f i o t c v w e j
t a n g l e o l k
s z g t s w u n g

Word Bank

cling

strong

thing

hang

belong

tangle

swung

strung

pick 3 words from the word bank.
Write a sentence using each word.

1. _____

2. _____

3. _____

Name _____

S T A M P I T

Words with "ng"

Look at each picture. Use stamps to spell the word that names each picture.

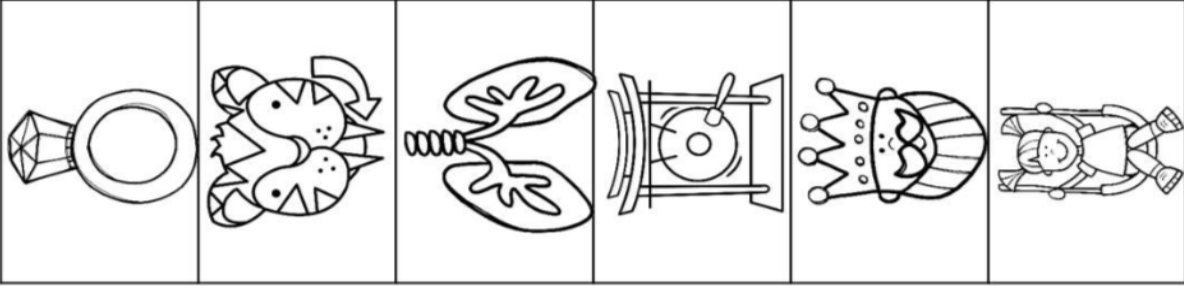

On the Ning Nang Nong
by: Spike Milligan

On the Ning Nang Nong
Where the cows go "Bong!"
and the monkeys all say "Boo!"

There's a Nong Nang Ning
Where the trees go "Ping!"
And the tea pots jibber jabber joo.

On the Nong Ning Nang
All the mice go "Clang!"
And you just can't catch 'em when they do!

So it's Ning Nang Nong,
Cows go "Bong!"

Nong Nang Ning,
Trees go "Ping!"

Nong Ning Nang,
The mice go "Clang!"

What a noisy place to belong
Is the Ning Nang, Ning Nang, Nong!

Name: _____

Date: _____

ng

rung

_____ rung

hang

_____ hang

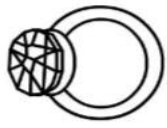

string

_____ string

ring

song

_____ song



hang



so

bri



ri

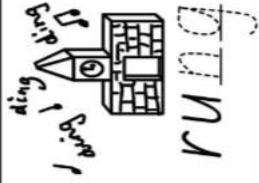
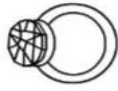

rung



stri



wi

lo



Long

long

long

long

Bring a long string.



Bring

Story Elements Organizer

Characters



Setting

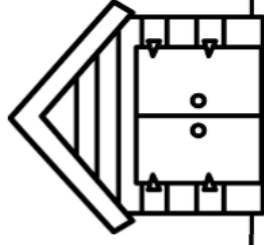









Problem

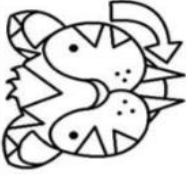
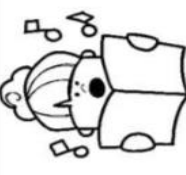
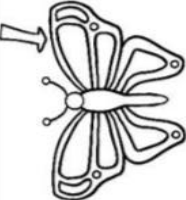
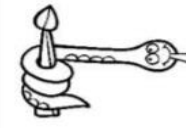

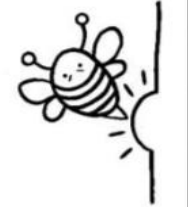

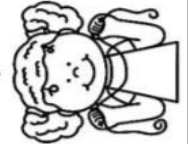
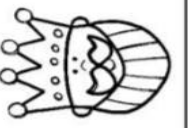

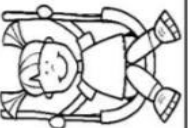
Solution

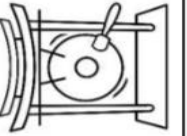
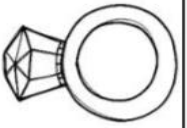

Picture Sort (Day 1) and Word Sort (Day 4): See lesson plan page for directions.

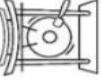
Words like 	Words like 	Words like 	Words like 
bang	ring	gong	lungs
king	long	clung	wing
hung	swing	strong	bring
rang	rung	bong	sprang
song	thing	sang	wrong
			fang
			stung
			sing
			sung
			hang

QR Codes for English

ng Sound Monday



ng Sound Tuesday



EPIC Reading

You will still need the code – mkz7198 to sign in.



Decodable readers



You will still need your username and password to sign in.

Volume Thursday



Capacity Friday

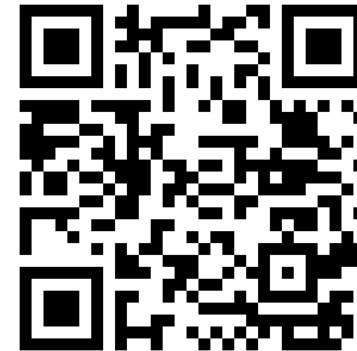

are

other

many

out

ng

0	1	2	3	4
5	6	7	8	9
10	11	12	13	14

15

16

17

18

19

20

Name: _____

Date: _____



Volume and Capacity

Colour the item that holds less.

spoon



jug



bucket



cup



wheelbarrow



bucket



kettle



bucket

spoon



vase

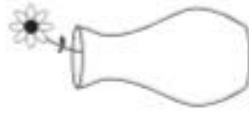

bucket



bowl



carton



bucket









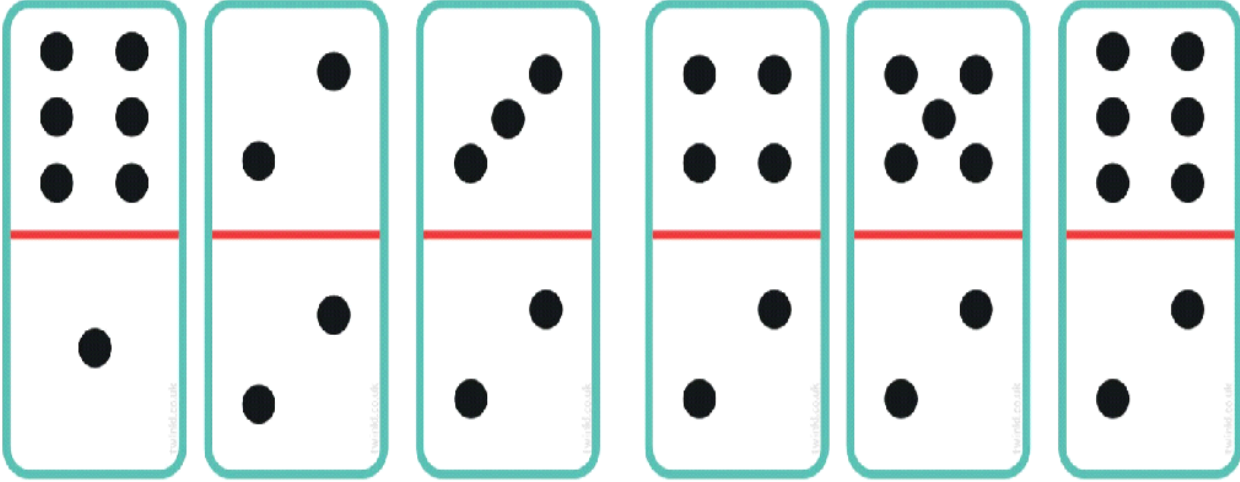
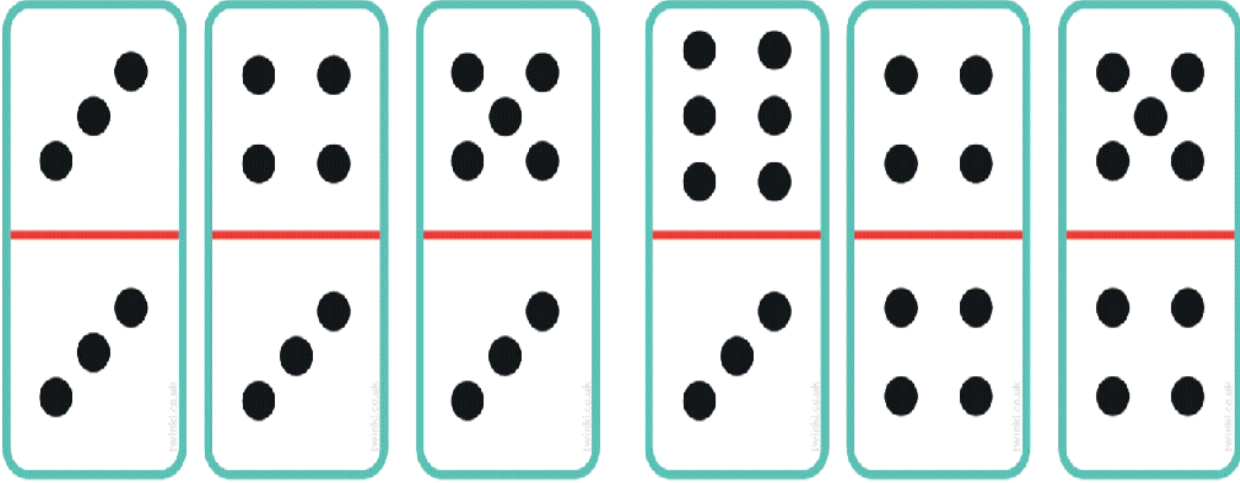

vase



trashcan

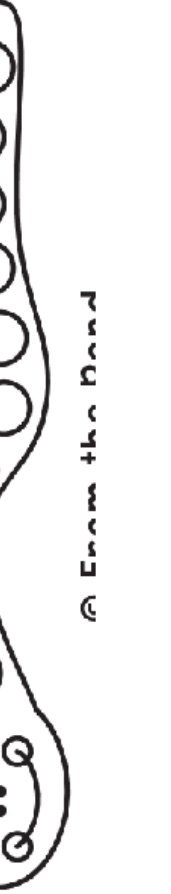

Let's Make Ten

1		9
2		8
3		7
4		6
5		5
6		4
7		3
8		2
9		1

Monster Colour by Number

Solve the calculations in the picture to work out what colours they should be.

10 = red

8 = pink

6 = green

4 = grey

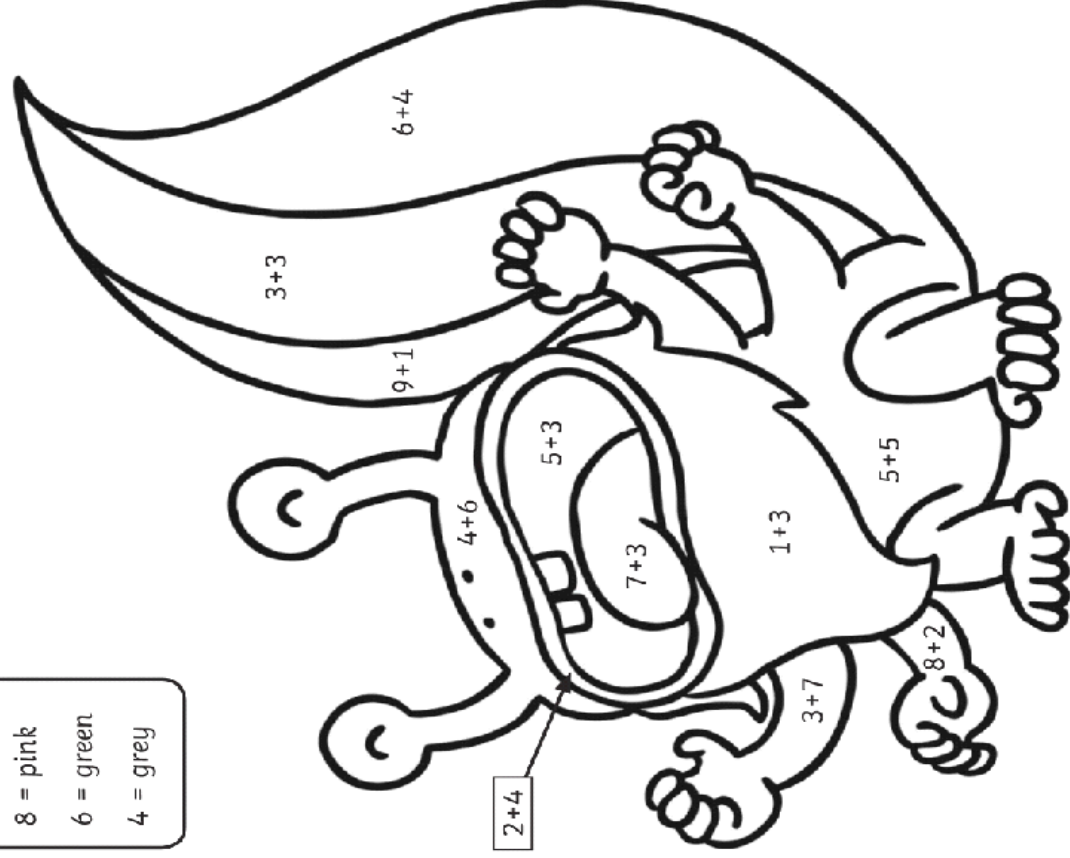

Spring

The Very Hungry Caterpillar

A numbers and skip counting activity based on the book *The Very Hungry Caterpillar* by Eric Carle.

Create a Numbers Caterpillar Collage

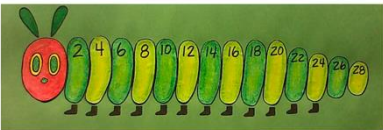
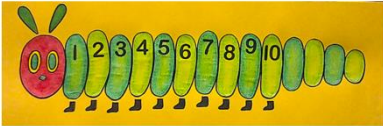

Using the template below, make a hungry caterpillar. Use colour and choose what numbers you would like to count. Example 1-10, or 10-20 or maybe counting by 2's. You could even write your numbers backwards from 20 or 10. When completed, use your caterpillar to practise counting.

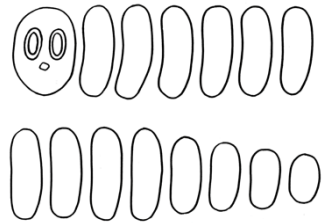

Tissue Paper Flower Craft for Kids



BuggyandBuddy.com

Create a tissue paper flower. You will need:
Strip of paper – coloured green or use pencil to colour.
Soft paper or tissue paper in different colours
Glue

To make:
Cut out the strip of paper for the stem and glue it on paper.
Cut or tear of small piece of tissue paper and scrunch into a ball.
Glue the tissue paper above the stem in a circle shape until a flower has been created.

Name: _____

Copycat Butterflies

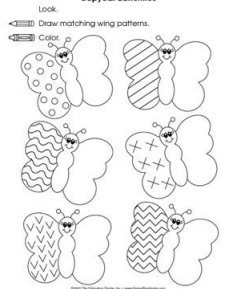

Draw and colour matching wings on the butterflies.

What happens in Spring? Do the leaves grow back on the trees? Do the flowers grow? Are baby animals born? Write a sentence about Spring.

Eg: I can see all of the leaves growing on the tree.

Draw a picture to match your sentence. Share these on Google Classroom.

Spring Following Directions Worksheet



Follow the directions on the Spring worksheet



Water the Flowers Alphabet Activity

Draw flowers with chalk on concrete. Write your sounds on the flower. Practice your sounds as you water the flower

My Strengths and Challenges

Task: List 5 different strengths that you believe you have, followed by 5 challenges you face in the boxes below. Then choose one strength and explain how it helps you feel confident at a particular thing. Finally choose one challenge and explain how you could use some help to turn it into a strength.

My Strengths:



My Challenges



I feel confident at:

I need help with:

Eating and Drinking

<i>I eat...</i>	_____ <i>eats...</i>
<i>I drink...</i>	_____ <i>drinks...</i>

Thumbprint Leaves

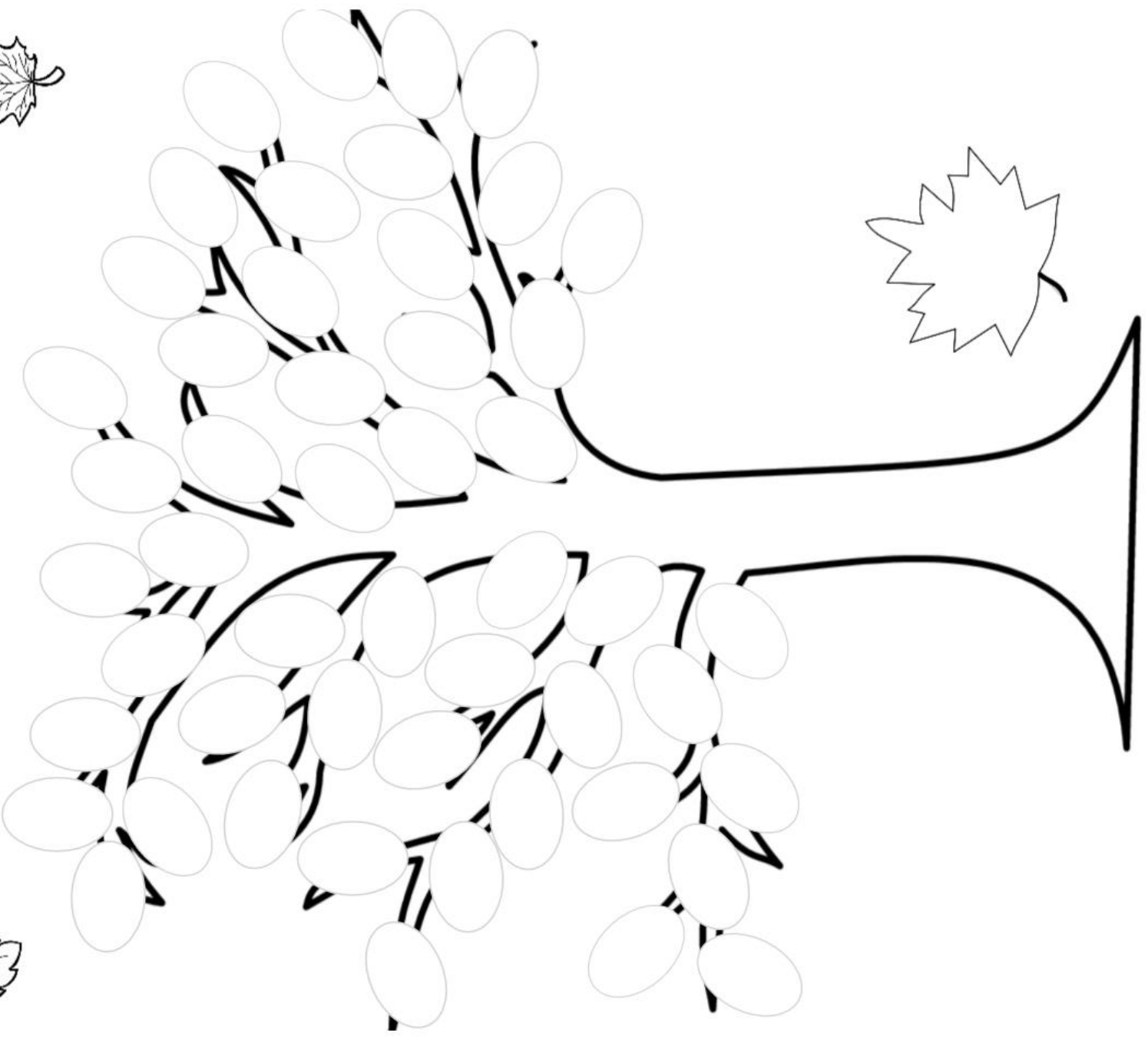

Name _____

Flights Of Fancy
Visual perception/fine-motor

Copycat Butterflies

Look.



Draw matching wing patterns.



Color.

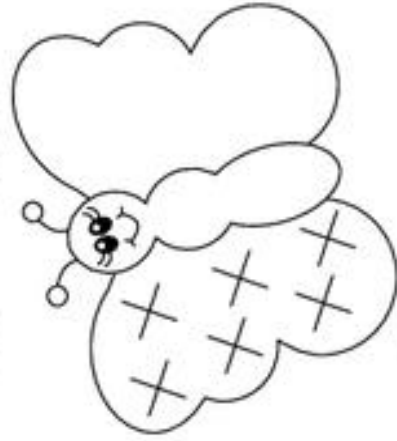
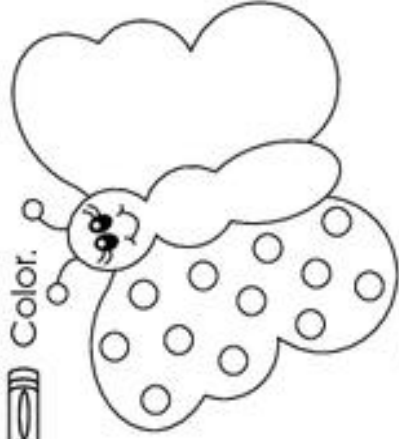

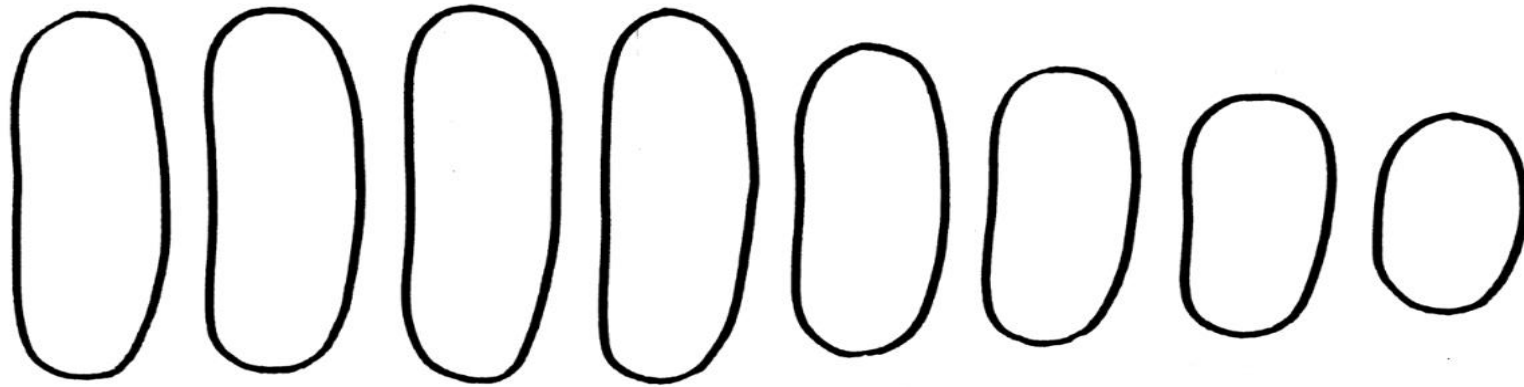
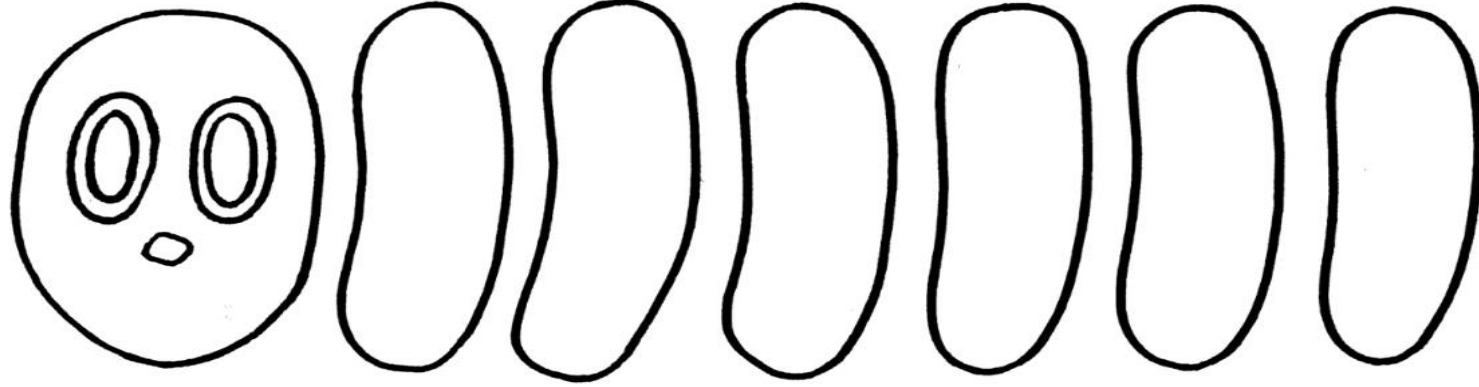

Name _____

www.kindergartenworksheets.net

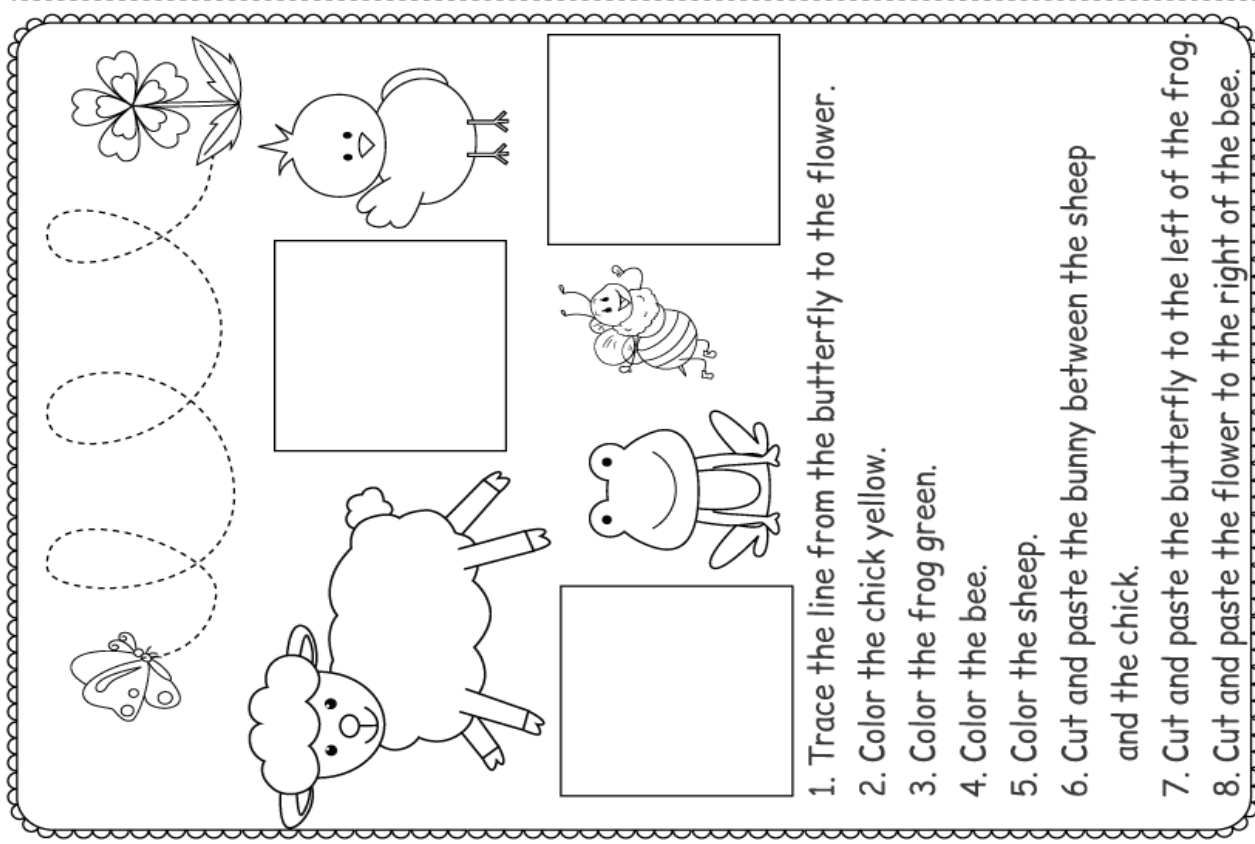

1. Trace the line from the butterfly to the flower.
2. Color the chick yellow.
3. Color the frog green.
4. Color the bee.
5. Color the sheep.
6. Cut and paste the bunny between the sheep and the chick.
7. Cut and paste the butterfly to the left of the frog.
8. Cut and paste the flower to the right of the bee.